

ACCUPRO® DROP

Manual

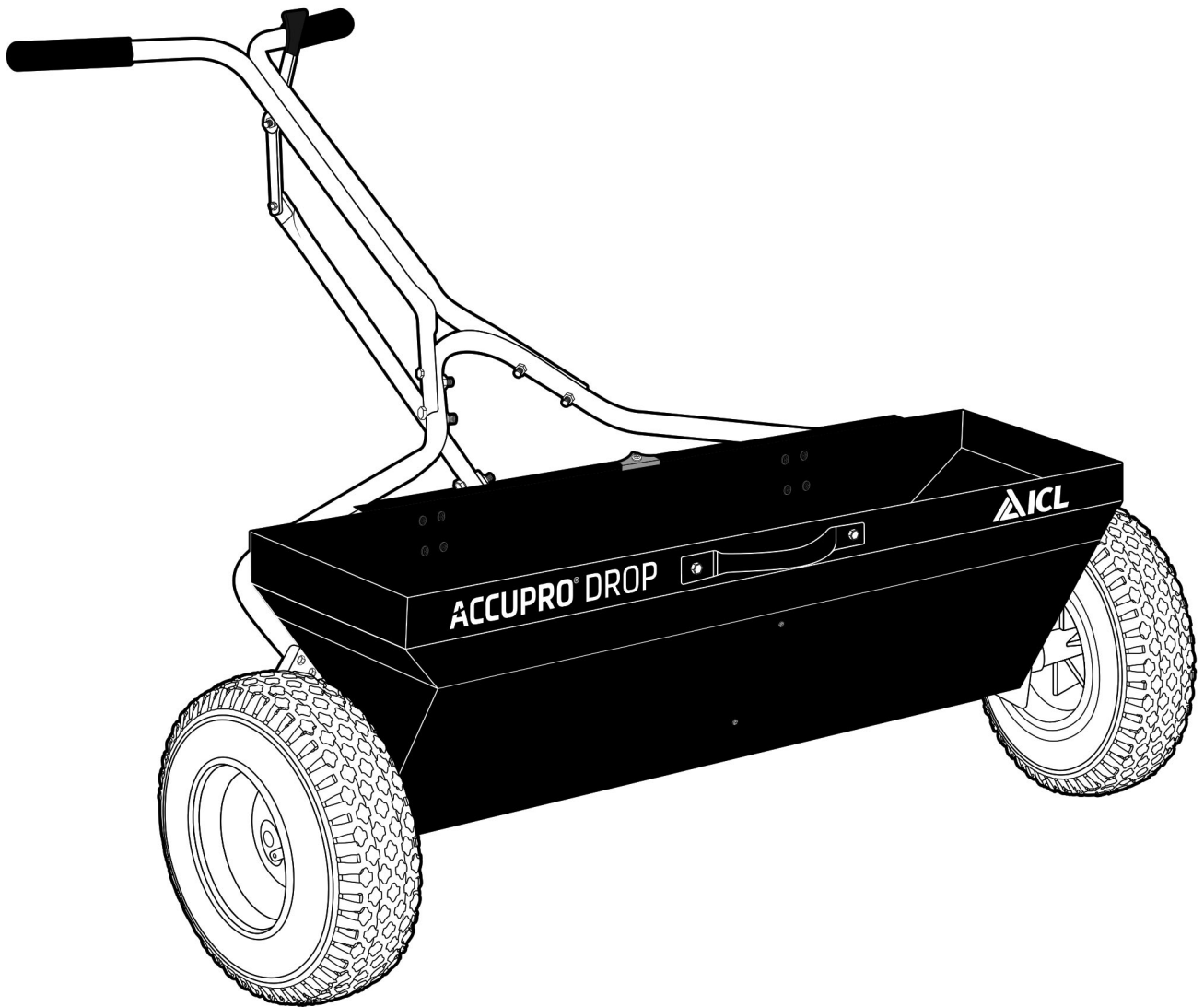

Spreader Parts

MAIN PARTS (Part images not to scale)

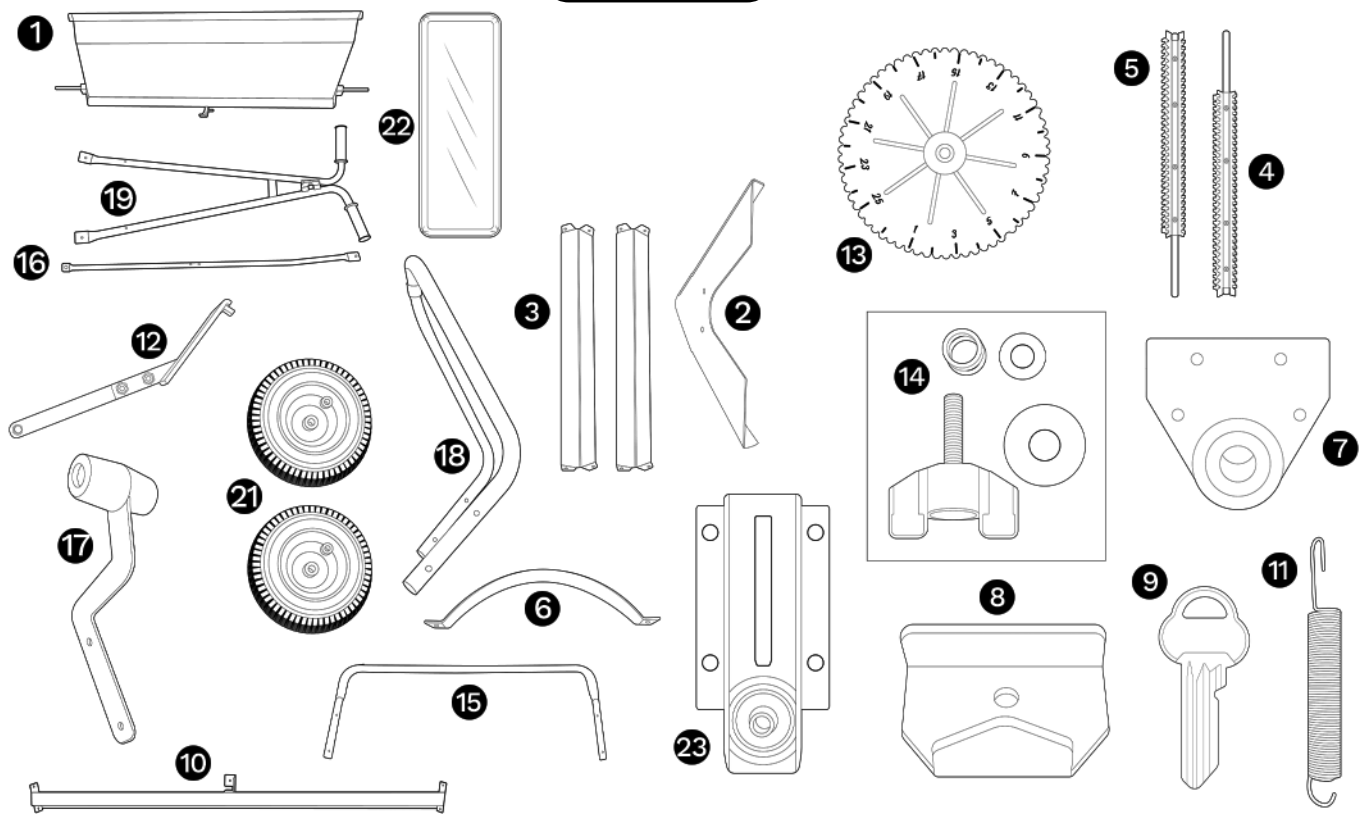

FASTENERS PACK CONTENTS

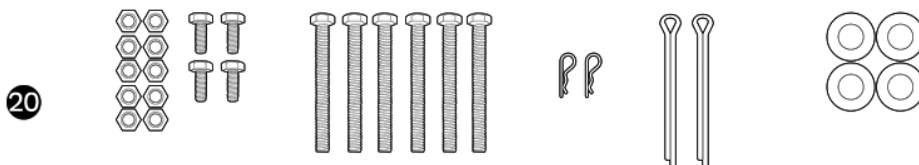

- 10 × M6 lock nuts
- 4 × M6×15
- 1 × M6×20
- 6 × M6×60
- 2 × Large cotter pins
- 4 × Backing washers
- 2 × Small R pins

Unbox and prepare for assembly; your spreader arrives partially assembled. To complete the setup, you'll need to attach the handle parts, back stand, and wheels to the hopper. Check all the parts are present before commencing attaching, the box contains the following parts:

ACCUPRO DROP parts list

- 1. Main Hopper
- 2. Hopper internal separator plate (includes 6 × M6×15 bolts and 6 × nuts)
- 3. Left and right baffle plates (including 8 × M6×15 bolts and nuts)
- 4. Agitator assembly right
- 5. Agitator assembly left
- 6. Lifting handle
- 7. Agitator to hopper mounting bracket × 2
- 8. Dial-direction arrow
- 9. Calibration check key
- 10. Shutter off bar
- 11. Spring
- 12. Linkage
- 13. SmartDial
- 14. Thumb screw spring and washer
- 15. Hopper stabilizing bracket
- 16. Main control rod
- 17. On/off lever
- 18. Back Stand
- 19. Main handlebar
- 20. Nuts and bolts (assembly pack) includes cotter pins, R pins and Calibration key
- 21. Wheels × 2
- 22. Rain cover
- 23. Back Plate

Assembling your **ACCUPRO DROP**

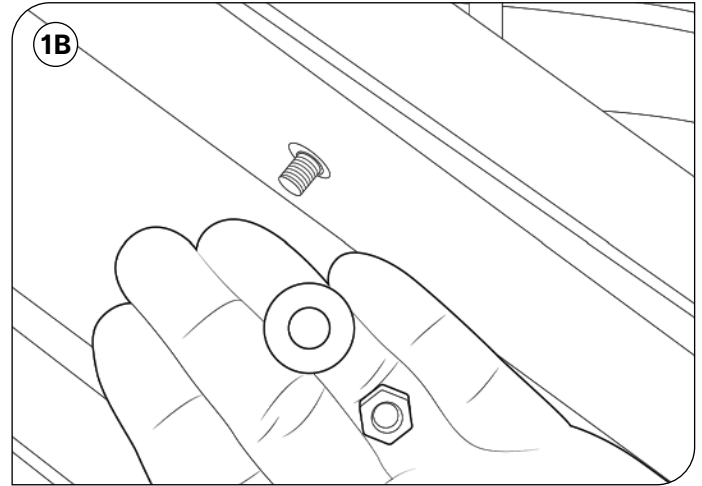
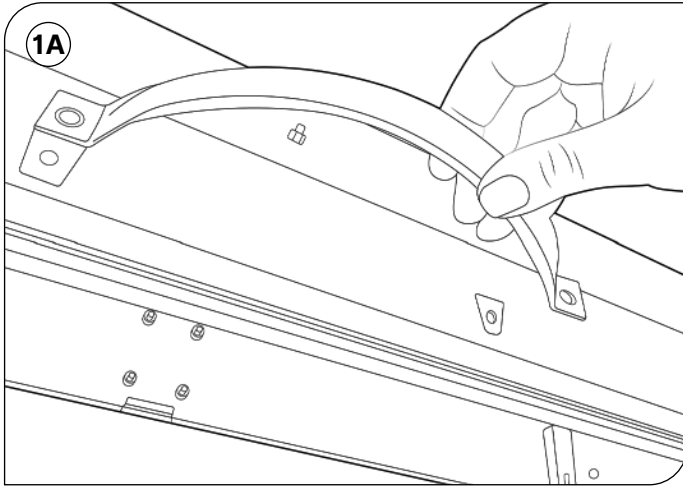

Attach the lifting handle (part 6) to the hopper body as shown. Using 2 × M6×15 bolts, 2 × Backing washers and 2 × lock nuts, affix the lifting handle via the two holes on the front of the hopper and tighten the lock nuts.

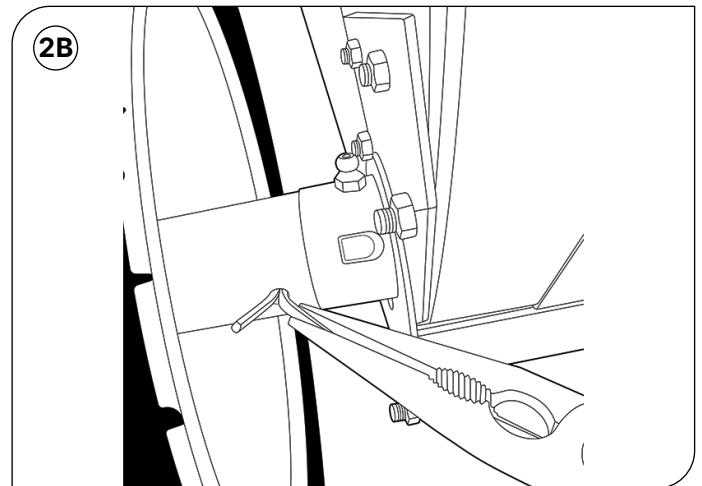
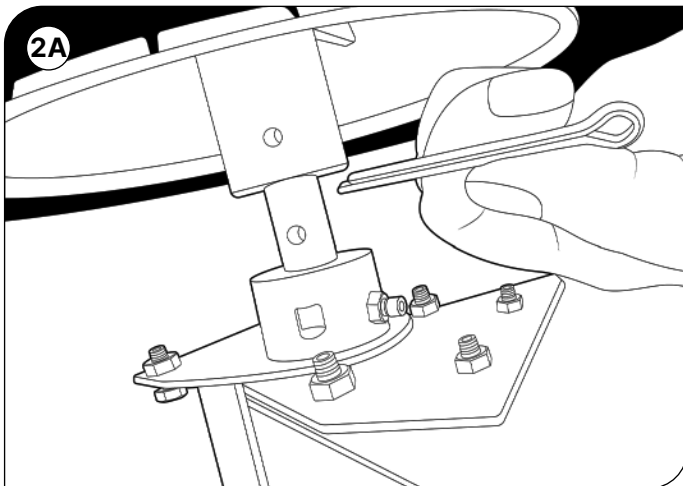

Using the 2 × Cotter pins attach the wheels to the two axles. Line up the hole in the wheel hub with the hole in the axle. Push the cotter pin through the hole. Using a pair of grips, split the cotter pin as shown to secure the wheel to the axle. Repeat on the opposite side to attach the second wheel.

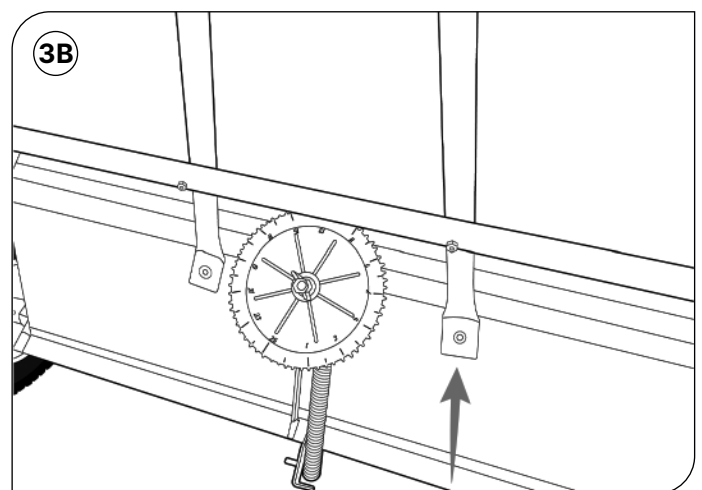
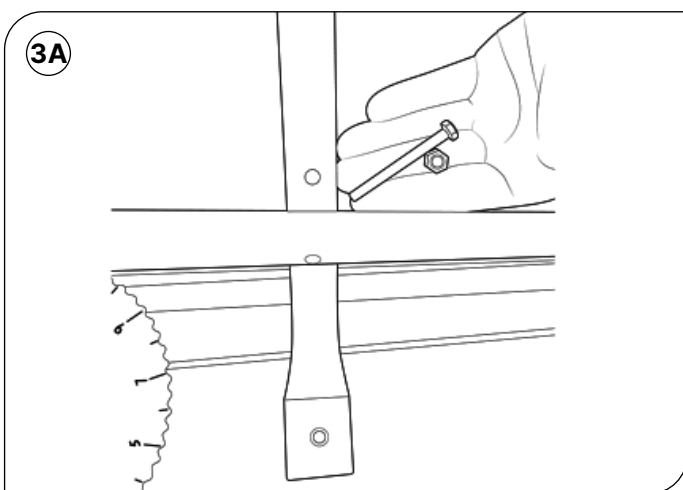

Attach the main handle section to the hopper. Using 2 × M6×60 bolts and 2 × lock nuts, place the main handle section between the hopper and the hopper stabilizing bar, locate the two bolts and loosely fix the nuts in place as shown in step 3A. Do not fully tighten. Using the 2 × M6×20 bolts, 2 × washers and 2 × lock nuts, secure the lower part of the main handle to the hopper as indicated in step 3B above.

Assembling your **ACCUPRO DROP**

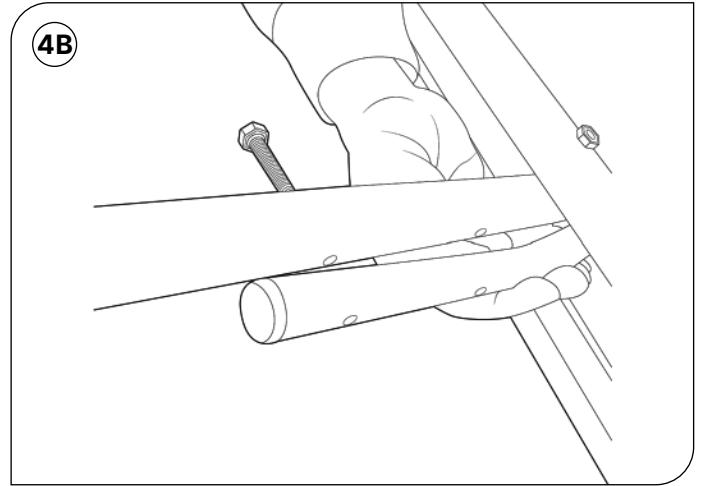
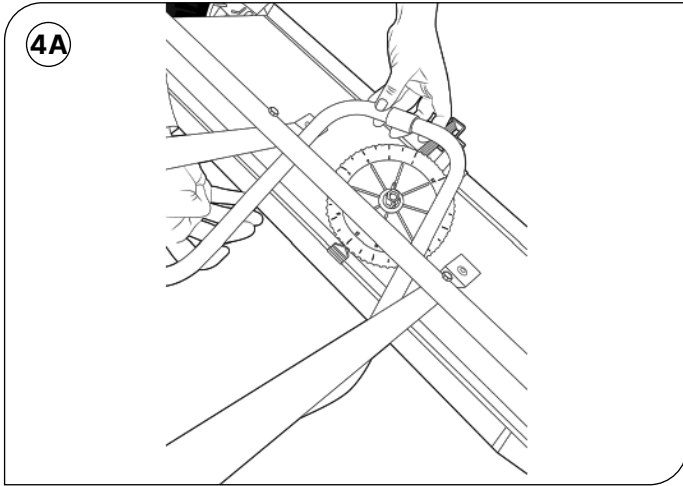

Attach the back stand to the handle. Feed the back stand through the space between the main handle and the hopper as shown in step 4A. Using 4 × M6×60 bolts and 4 lock nuts secure the back stand to the handle and tighten the lock nuts (step 4B). Now tighten all the lock nuts attaching the main handle to the hopper and the hopper stabilizing bar.

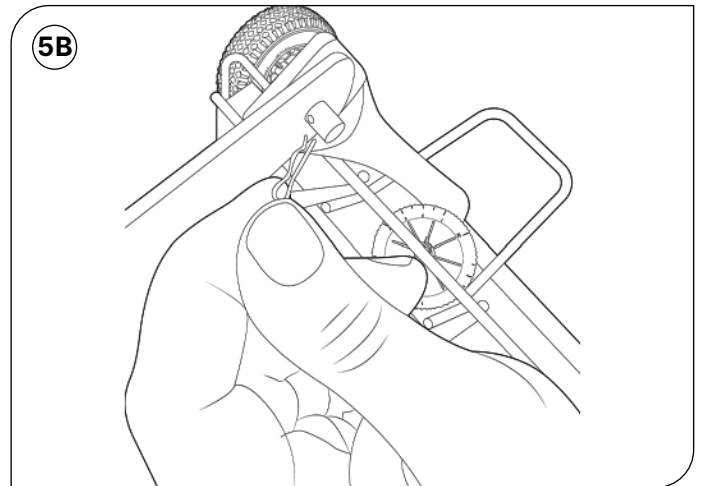
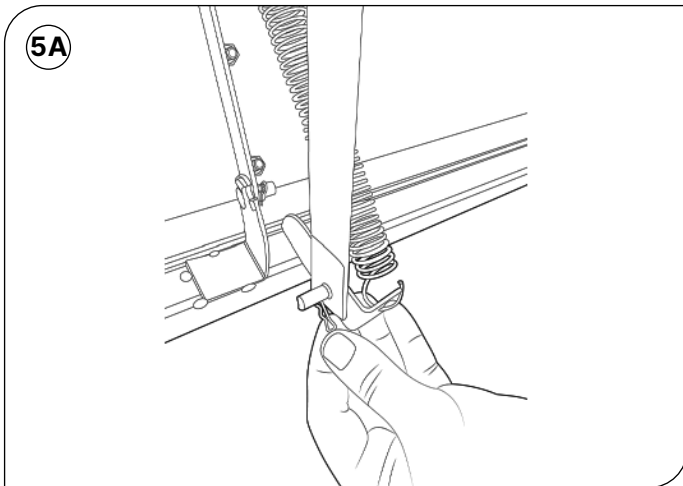

Attach the control rod. The control rod has a bend in it. **IMPORTANT:** Make sure the bend faces towards the ground. Locate the control rod lower end (bend facing downwards) onto the round dowl and affix with 1 × small R pin as shown. Repeat at the top of the handle using the second small R pin as shown.

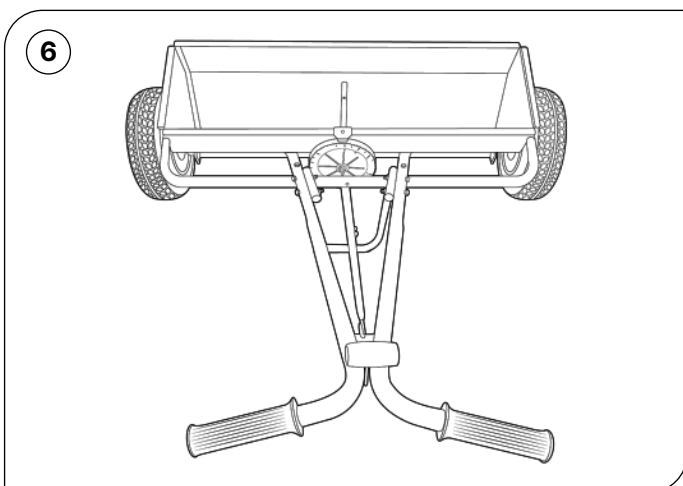

The ACCUPRO DROP is now fully assembled. Before use, it is advised to grease the two grease nipples located between the wheels and the hopper to ensure smooth running.

How to use the **ACCUPRO DROP**

The ACCUPRO DROP is designed for application of seed, fertilizer and other free flowing materials for accurate application to turf. To optimize the effectiveness of this spreader, follow the guide below.

Step 1: Before using the spreader, ensure it is clean and free of debris from prior usage by conducting a thorough inspection.

Step 2: Check the material to be used is in good condition, free flowing and compatible for use in a precision drop spreader.

Step 3: Setting the aperture

Place the on/off lever in the closed position. (Towards the handle grips) Using the orange control dial, loosen the center thumb screw allowing the dial to turn, rotating the dial to the desired position for the required application rate utilizing the 1 to 25 scale. Once the required application rate number is lined up against the arrow on the hopper turn the thumb screw clockwise to lock the desired setting in place. Further information on application rates of specific ICL products can be found on the ICL web sites or through ICL appointed retailers.

Step 4: Filling the hopper

Ensure the control lever remains in the off/closed position (towards the handle grips) before filling the hopper. Fill the hopper uniformly across its entire width. Always fill the hopper in a safe place away from areas where any accidental spillage while filling could cause damage.

Step 5: Spreading material

The spreader should be pushed at a brisk walking speed of approximately 5 km/h. Access the area to be treated firstly it is advisable to apply a single header strip at each end of the area to be treated. Push the on/off lever forward to open the aperture at the same time as commencing forward movement. At the end of each run close the aperture by pulling the on/off lever back to the closed position. The spreader applies material between the wheels, making an overlap required. It is important to overlap the wheel tracks on each return pass to avoid striping.

Step 6: Cleaning and after-use instructions

Always empty any leftover product out of the spreader when application has been completed. Disposing of any excess material in the correct manner. Unused material in the hopper is best emptied by inverting the spreader. Further action maybe required to clear any leftover material if required. Rotate the orange SmartDial to fully open (setting 25). Lift slightly the left wheel and rotate it so the agitator turns and ejects any trapped product. Repeat the operation with the right wheel to clear any trapped product on the right side.

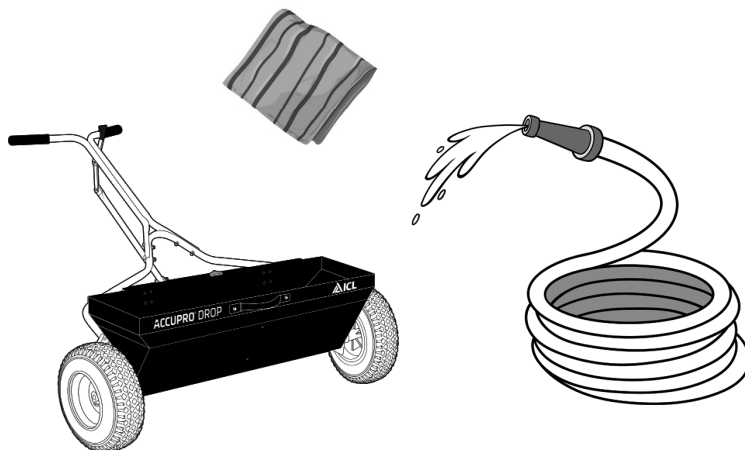

Wash the hopper thoroughly with clean water particularly the area around the two agitator bars inside the hopper and the on/off shutter bar. Make sure the hopper is dry before any further use of the spreader.

ACCUPRO DROP Calibration key

Calibration is factory set on the spreader. The spreader has two independently working agitators driven by the left and right wheels feeding the left and right sides at the exit point of the hopper. The agitators are evenly distributing and pushing material out through the aperture. Periodically check that the right and left sides of the spreader's outlet area are perfectly aligned. A check key is supplied with the spreader.

For more information on how to use the calibration key, please visit the ICL website:
<https://icl-growingsolutions.com/turf-landscape/>

ACCUPRO DROP Application rates

The ACCUPRO DROP is designed to apply different material types at accurate rates.



Scan the QR-code on your fertilizer bag to find out the recommended g/m^2 and spreader application settings.

If you experience any issues finding the correct spreader settings or application rates, please get in contact with your ICL sales representative. Information on settings for all ICL products can be also found on the ICL website: <https://icl-growingsolutions.com/turf-landscape/>

3-Year Limited Warranty

This product is warranted to be free of defects in original workmanship and materials for a period of 3 Years from the date of purchase by the end user, as evidenced by the original dated purchase receipt.

Should a manufacturing non-conformance be identified, the manufacturer will repair or replace the part(s) or product at its discretion at no charge, provided the failure is not due to incorrect installation, mishandling, misuse, tampering, or normal wear and tear as determined by the manufacturer.

The manufacturer may, at its discretion, require that the part(s) or product, along with the original purchase receipt, be returned at the owner's expense for examination and compliance with the terms of this warranty.

Do not return any product without first receiving authorization. To seek remedy under this warranty, contact the manufacturer at the provided contact number or email address and describe the nature of the manufacturing defect.

Specific limitations

This warranty covers only the part(s) or product; any labor charges associated with the repair or replacement of non-conformances are specifically excluded. Due to the corrosive nature of most fertilizers and ice melt products, the manufacturer makes no warranty against and specifically excludes part(s) or product degradation or failure due to corrosion or its effects.



To mitigate the effects of corrosive materials on your product, clean and dry your spreader or seeder thoroughly after each use. As a further preventative measure, coat all metal parts with a light oil or silicon spray.

ICL Growing Solutions
Koeweistraat 4, 4181 CD Waardenburg
The Netherlands
Tel.: +31 (0) 418 655 700
Email: marketing.int@icl-group.com

For further information contact your
ICL Technical Area Sales Manager
or visit www.icl-growingsolutions.com



MKT-0423

